

SITE SURVEY & PREPARATION GUIDE

for the
Spectrum Engraver

Congratulations on your Spectrum purchase. Ohio Gravure Technologies wants to provide you with the best possible service before, during and after installation of your new equipment. To help us achieve this, we are providing this *Site Survey and Preparation Guide*. We hope this guide answers the questions you will have about equipment requirements and other items of interest.

Important! Some of the items in this list require sending information to Ohio Gravure Technologies. This information must be returned as soon as possible. Failure to return the information could delay shipment or slow down the installation of equipment.

The objective of this Site Survey and Preparation Guide is a smooth installation. By satisfying the criteria and requirements presented in this guide, you will be well on your way.

What Is In This Guide

This Site Survey and Preparation Guide is designed to provide details necessary in defining and preparing a site for your new Ohio Gravure Technologies equipment. Use this information with the *Site Preparation Checklist* (next page) to ensure that all of the equipment needs are met. When the checklist is complete, you will have:

- chosen a suitable location for the system
- learned of the specific power requirements
- become aware of the system's environmental requirements

This guide is divided into sections:

- The first section, *Cylinder Specifications and Screen Information*, ensures that your cylinders will fit into the drive option ordered.
- The next section, *Site Requirements*, contains information on preparing your site for your engraver and for a Collage computer
- The next section details *Unloading Requirements* and information on *Moving the Machine*
- The next section, *Cylinder Information*, contains information on preparing cylinders
- The last section contains specifications for engravers and cylinders.

If You Have Questions

This guide contains information on Ohio Gravure Technologies equipment, but we know there may be questions that are not answered by this guide. Specific questions on your order may be directed to your sales agent or contact Ohio GT: sales@ohiogt.com

Site Preparation Checklist

- Before the equipment arrives, verify that: Complete
1. You have sent cylinder drawings to verify compatibility for chucks or cones. See *Cylinder Specifications* on page 3

You have sent your input voltage requirements. See *Machine Input Voltage Requirement* on page 4
 2. A loading dock or other suitable location is available for delivery and uncrating of the equipment. See *Unloading Requirements* on page 12.

If no loading dock is available to unload the equipment, contact Ohio Gravure Technologies's Customer Support or your agent.
 3. Lifting equipment is available for:
 - lifting the equipment off the skid
 - moving the equipment to its final position

Refer to page 11 for information on the physical dimensions and weight of the engraver.
 4. An adequate path exists for moving the equipment from the loading dock to its permanent location. Remember door openings if they are in the path.
 5. Electrical requirements (see *Electrical Requirements* on page 7)
 - A. Sufficient power and electrical sources exist to meet the specifications for all system components and options.
 - B. The distance from the UPS and the Ohio GT equipment is 10 m (32 ft.) or less.
 - C. The voltage and amperage rating of the power line(s) match the input power requirements of the equipment.
 - D. A dedicated ground line is within 3 m (10 ft.) of any PC's purchased. See *Special Requirement for PC Equipment* on page 8.
 6. Equipment location (see *Environmental Requirements* on page 8)
 - A. Adequate temperature and humidity controls are available to maintain the environmental requirements. See *Table 2 Equipment Cooling Requirements* on page 1-9.
 - B. The location for equipment meets the vibration requirements. See *Table 3 Vibration Specifications* on page 9.
 - C. The structure/location is capable of handling the load of the equipment.
 7. Your copper plating and finishing equipment is adequate for producing cylinders for engraving. See *Cylinder Plating and Finishing* on page 22.

When all conditions are met, please sign this checklist and fax a copy to Ohio Gravure Technologies (+1 937 439 1592) or scan and email to service@ohiogt.com

 Customer Signature

 Date

 Company Name

 Address

Machine Input Voltage Requirement

The Spectrum engraver requires 220 or 230 or 240 VAC (+/- 3%) single phase, 50 or 60 Hz. It is important that the machine is wired for *your* specific input voltage.

Please complete below and fax to Ohio Gravure Technologies (+1 937 439 1592) or email to service@ohiogt.com

My Input Voltage is

220V

230V

240V

Customer Signature

Date

Company Name

Address

See page 7 for more information on electrical requirements.

Cylinder Specifications & Screen Information

By providing us with the exact specifications for the cylinders you will use in your new Spectrum, we can ensure the cylinders will fit with the specific fixtures on your machine. It is best if you can send us drawings of your cylinders. If you cannot, please provide the following information. All dimensions should be in millimeters.

Shafted Cylinders

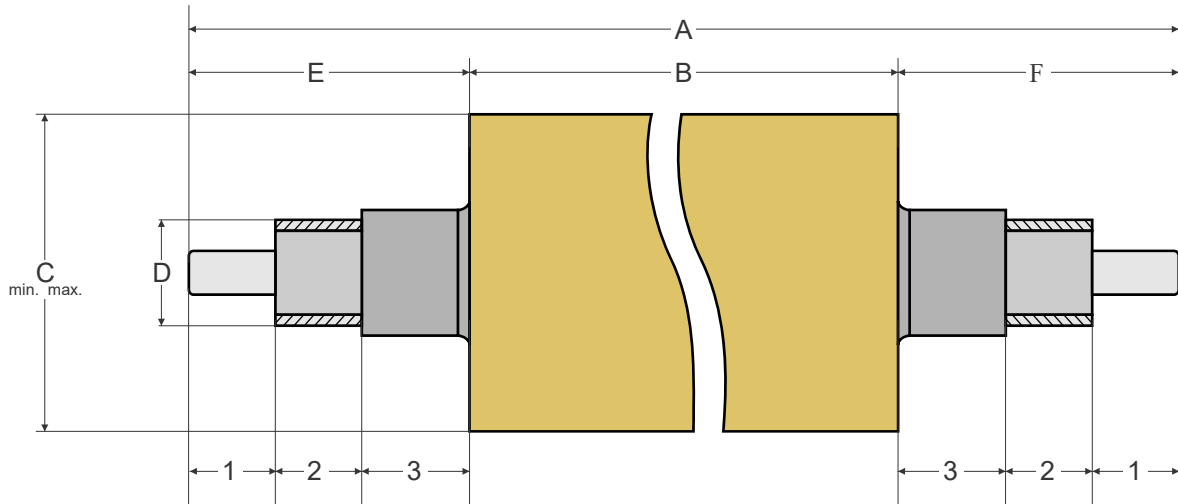

2 = Press surface

Cylinder ID	A	B	min. C	max.	D	E	F	1	2	3

Please fax to Ohio Gravure Technologies (+1 937 439 1592) or email to service@ohiogt.com

Customer Signature _____

Date _____

Company Name _____

Address _____

FOR COMPANY USE ONLY
OHIO Mechanical Engineering Review

Signature _____

Date _____

Shaftless (Hollow) Cylinders

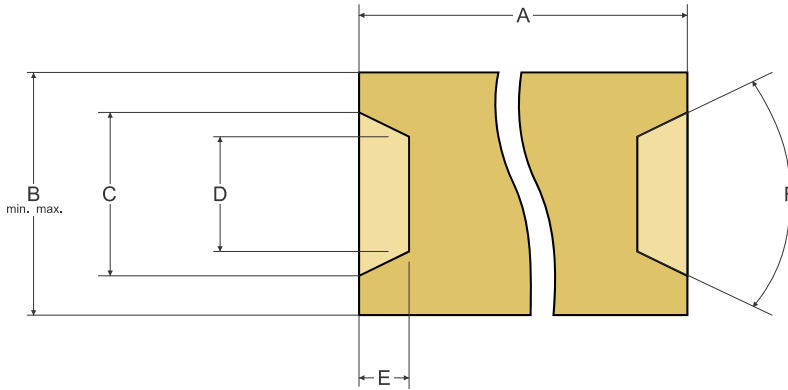

Cylinder #	Press	A	min. B	max.	C	D	E	F

Common Screen/Angle/Stylus

Please let us know your most common screens, angles, and styli. These will be programmed into the machine during factory ATP acceptance testing.

Screen	Angle	Stylus	Full μ	Highlight μ	Channel μ	Mid1 μ	Mid2 μ

Please fax to Ohio Gravure Technologies (+1 937 439 1592) or email to service@ohiogt.com

Customer Signature _____

Date _____

Company Name _____

Address _____

FOR COMPANY USE ONLY
OHIO Mechanical Engineering Review

Signature _____

Date _____

Site Requirements

This section provides information on the site requirements for a Spectrum engraver and for a Collage Layout System computer.

Engraver

The following are the requirements for the engraver. See engraver dimensions on page 23.

■ Pneumatic Supply

Spectrum engravers with automatic chucks require a minimum pressure of 586 Kilopascals or KPa (85 PSI). Additionally, the air supply should have a minimum reserve capacity of 19 liters (5 gallons) per engraver.

Connection of the pneumatic device to the air line should be done using flexible tubing and a quick disconnect coupling.

The flexible tubing – nylon is recommended – must be rated at 1000 KPa (150 PSI).

Contact Ohio Customer Support for additional information.

■ Electrical Requirements

If you have any questions on the electrical requirements or if you do not have the electrical service available to you as listed below, contact your Ohio GT representative.

Circuits Required for Spectrum Engraver

The Spectrum requires the following:

	Power	Voltage	Frequency/Fuse
Power Supply	5.00 kVa	1x220V +/- 3%	50/60 +/- 1%25A
	5.00 kVa	1x230V +/- 3%	50/60 +/- 1%25A
	5.00 kVa	1x240V +/- 3%	50/60 +/- 1%25A

Table 1 Electrical Requirements

Maximum wire length from UPS to Ohio GT's equipment is 10 meters (32 feet). Minimum wire size for this length is 3 mm (#8 A.W.G.). If your application requires a length longer than 10 meters, please contact your local electrician for appropriate wire size.

Every power device (UPS) must have its own dedicated ground line. Ohio GT recommends the ground line be attached by its own clamp to the building frame whenever possible. Failure to ground to the building frame may cause voltage spikes on the ground line, possibly damaging the equipment or causing intermittent operation problems.

UPS Information

Voltage must be isolated through a double conversion type of Uninterruptible Power Supply (UPS). Connection of input power source to UPS and from Ohio GT’s equipment to UPS is the customer’s responsibility

An independent earth ground must be provided at the input power source to the UPS.

This guide will assist you in determining the UPS size needed for your system:

Equipment	Power Req'd	Circuit Req'd	UPS*
Spectrum Engraver	3.5 kVA	30 A	5 kVA
Collage Layout Workstation	1.0 kVA	15 A	1.4 kVA

*Table 2 UPS Requirements
Double Conversion Type required

Special Requirement for PC Equipment

A dedicated ground line must be located within 10 m (30 ft.) of any PC system. See drawings referenced below.

System Grounding

See included drawings for Ohio GT’s grounding practices (end of this document):

- 9400-0002 — 100-240 VAC 50/60 Hz UPS Installation

■ **Environmental Requirements**

Areas with Ohio GT equipment should be kept clean and orderly.

Air Quality

Proper operation of the engraver requires air quality that matches a typical urban environment as designated by ISO 9, room air:

ISO 14644-1 cleanroom standards

Class	maximum particles/m ³						FED STD 209E equivalent
	≥0.1 μm	≥0.2 μm	≥0.3 μm	≥0.5 μm	≥1 μm	≥5 μm	
ISO 9	1.0×10 ⁹	2.37×10 ⁸	1.02×10 ⁸	35,200,000	8,320,000	293,000	Room air

Table 3 Air Quality Standards

Allowing a few more particles in a factory setting is reasonable, but excessively dirty environments will cause problems with the engraver. While all parts of the engraver with fans or blowers require clean air, the engrave head is extremely sensitive to dirty air. Excessive build-up of dirt in the engrave head will cause it to cease working properly.

Engrave head repair because of excessive dirt is not covered under warranty.

Air Conditioning/Humidity Requirements

Recommended operating temperature range	20-25° C (68-77° F)
Recommended relative humidity	40-65% non-condensing

Table 4 Environmental Temperature

Heat Dissipation

To help assist you in determining the air conditioning needed, the cooling requirements for the equipment are as follows: (BTU = British Thermal Units 3412 BTU's = 1KWhr)

Spectrum Engraver	12,000 Cooling BTU
-------------------	--------------------

Table 5 Equipment Cooling Requirements

■ Floor Load

Floor bowing under load	0.2 mm/m Execution according to DIN 18202
-------------------------	--

Table 6 Floor Load Requirements

Do not use intermediate floors or support beams as machine foundation

■ Vibration Specifications

Your Ohio GT equipment should be placed in a location free from excessive vibration. Vibration can be generated by nearby equipment or cylinder carts with metal wheels and from installing the equipment on inadequate flooring. The required vibration criteria for machine foundation is the VC-A standard for general laboratory conditions, or the following table:

Maximum allowable floor vibration	Peak to Peak Amplitude		Frequency
	Microns	Micro inches	
	3.8 µm	150	2-8 Hz
	2.5 µm	100	9-15 Hz
	1.5 µm	60	16-21 Hz
	1.0 µm	40	>21 Hz

Table 7 Vibration Specifications

Vibration measurements are taken using an accelerometer. Contact an instrumentation company that has an accelerometer to evaluate your site.

■ Lighting Considerations

The following is a recommended minimum standard for illumination:

The room containing the engraver should have a minimum of 2153 lumen/m² (200 foot-candles).

■ Noise

The engraver generates a sound of 85 to 90 db when engraving. The Spectrum enclosures provide a sound barrier to this noise. Ohio GT does not recommend operating the engraver with the enclosures open. If using the machine with the enclosures open, we suggest some type of ear plugs for your operator.

We do not recommend placing the Collage PC in the same room as the engraver.

■ Communication

Ethernet for Collage Interface to engraver (included with Collage computer).

Recommended: Internet connection, ideally via Collage computer, for TeamViewer remote support.

Collage Computer(s)

This portion details requirements for the Collage layout system.

■ Environmental Requirements

Lighting Considerations

The Collage PC should be placed in a room with lower light levels. Bright light will make it more uncomfortable for the operator who is sitting in front of the equipment for the day. Direct sunlight should be avoided. If the room has windows, curtains or blinds should be available to reduce the sunlight.

Air Conditioning/Humidity Requirements

Recommended operating temperature range is: 20-25° C (68-77° F)

Recommended relative humidity is: 40-65% non-condensing

Ohio GT strongly encourages that the room with the Collage layout workstation be temperature controlled.

Magnetic Fields

Avoiding placing the Collage workstations near electromagnetic fields. These fields can cause problems with the hard disk, computer monitor, and magnetic media (if used).

Noise

Ohio GT recommends that Collage layout workstations be placed in a location away from the engravers. The engraver generates noise during engraving that may be distracting to the Collage operator. Collage systems should be placed in a separate room to avoid this noise.

Ergonomics

The Collage layout workstation is the centerpiece of the Ohio GT system and the starting point for all cylinder layouts for engraving.

The person(s) assigned to operate the Collage layout workstation will be spending a large part of their day in front of the workstation. Because of the nature of the job, eye and back fatigue are possible. To reduce eye fatigue, position the equipment so the operator can look away and focus on something in the distance. Keeping the lighting levels down will also help prevent eye fatigue. For back fatigue, a chair providing good back support is a good start.

Unloading Requirements

The following information concerns how the equipment will show up at your door. If you have any questions about the shipping arrangements, contact Ohio GT Customer Support.

Ohio GT strongly recommends that you hire **professional movers** to remove the equipment from the truck and move the equipment to the final location.

For installation of the machine, an Ohio GT service technician must be on site, otherwise Ohio Gravure Technologies, Inc. refuses all responsibilities.

■ Domestic (U.S., Canada, and Mexico)

All equipment is shipped from Ohio Gravure Technologies in an enclosed truck. The easiest method for unloading is with a loading dock. If you do not have a loading dock, contact Ohio GT's Contract Administrator to arrange for a flat bed truck.

■ International (All other countries)

Machines are wrapped in anti-static plastic wrap, secured to a skid, and enclosed in a solid wood crate. Shipment from Ohio GT is normally by ocean going container. A loading dock allows the easiest removal of the equipment from the container. If you do not have a loading dock, contact Ohio GT.

Weight of the Machine

Important! Machine weight can vary depending on cylinder fixturing.

Model	Net weight (kg)	Net weight (lbs)
Spectrum Compact Engraver	4,291 kg	9,450 lbs
Spectrum Packaging Engraver	5,330 kg	11,750 lbs
Spectrum Decorative Engraver	6,838 kg	15,075 lbs
Spectrum Large Format Engraver	13,104 kg	28,890 lbs

Table 8 Machine Weight

For complete machine specifications, see later in this document.

How the Machine is Packed

To avoid damage, the machine is securely packed at Ohio. Doors are secured with packing material between the door frames to protect them from rubbing during transit. There are no pressure points between packing material and cables. During transport, no loose parts are allowed to be on the machine. All parts transported with the machine are fastened properly. The machine is wrapped in plastic to keep out moisture and prevent dirt. Small parts such as cables, the touchscreen monitor, computer(s), and the engrave head are packed separately.

■ Machine Skid and Crate

The engraver is bolted down to a skid sufficient for its weight. The machine and skid are completely encased in a sturdy, well-built wooden shipping crate. The crate is placed into the shipping container (if applicable). The crate is clearly marked with warning notices about proper handling. Ensure that these warnings are fully complied with.

■ Shipping Container

For international shipment, your equipment travels in a shipping container.

When shipping is handled by Ohio GT, the shipping container is reserved for our equipment. Our freight forwarder packs the container with the parts box and the crated engraver, and uses correct bracing to prevent any movement during transport.



The crated engraver is placed so that the heavy end of the engraver faces the container doors.

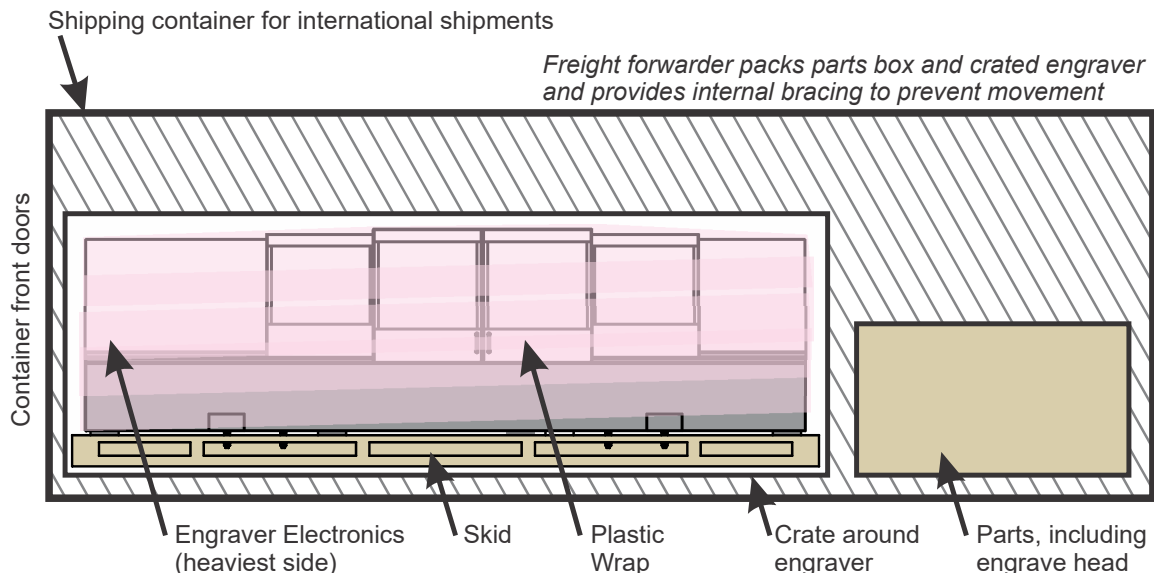

Arrival At Your Site

Ohio GT strongly recommends that you hire **professional movers** to remove the equipment from the truck and move the equipment to the final location.

For installation of the machine, an **Ohio GT service technician must be on site, otherwise Ohio Gravure Technologies, Inc, refuses all responsibilities.**

Equipment needed



**DO NOT lift or move the crate or the machine with a crane!!
Severe and unrecoverable damage to the machine could result.**

At least one forklift with a lifting capacity sufficient for the weight of the engraver must be available to move the engraver off the skid. One or more dollies with sufficient capacity may also be needed to aid in moving the machine into its final position.

The shipping container arrives at the site.



Use forklifts with sufficient lifting capacity to remove the crated machine from the container.



Removal of the Crate

When the crate with the engraver is available for inspection, carefully inspect the top and sides of the crate for damage. If any damage to the crate is found, do not proceed.

Shock indicators are attached to the outside of the crate. These should be carefully inspected. If a shock indicator shows that the machine has been subjected to excessive shock during transport or unloading, do not proceed. Contact your insurance company or Ohio GT customer support.



Not dropped



Dropped

It is the customer's responsibility to note on the shipping documents any damage to the crate or any packaging.

If no damage is found, carefully remove the top and sides of the crate. Retain these pieces until the engraver has been installed and accepted as working.



About the Skid

The Spectrum engraver is shipped on a skid. The machine is held to the skid using four tie-downs, two on each side. After the machine arrives at your facility and is uncrated, keep the machine tied down to the skid for as much of the move as possible.

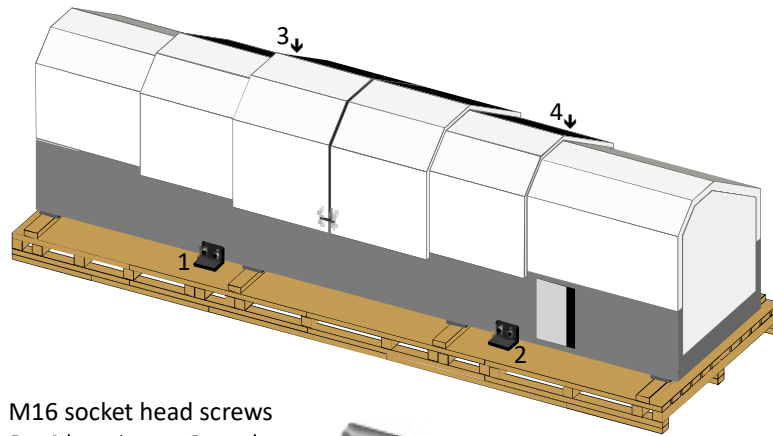

- A) M16 socket head screws
2 x 4 locations = 8 total
M14 hex bit to remove
- B) Lag bolts
2 x 4 locations = 8 total
24 mm wrench to remove

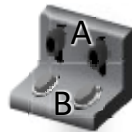

Note: The tie-down system shown is OHIO's current shipping method. The number of doors varies with the engraver model (packaging model shown).

Moving the Machine Into Position

Professional riggers experienced in moving heavy machinery must be used to move the Spectrum from the loading dock to its final location.

Use a forklift which is rated to move the weight of the machine.



**DO NOT lift or move the crate or the machine with a crane!!
Severe and unrecoverable damage to the machine could result.**

Lifting the Machine from the Skid

Important! You should not lift the machine using a forklift at the end with the electronics (this is the end with the Spectrum logo). Damage to the electronics could occur if you don't lift properly – you must use the correct fork length and insert the forks the correct distance under the machine.

Safest to Lift in the Center?

Optional cylinder supports may be installed in the machine and can impact lifting at machine center. The cylinder supports are visible as six tubes protruding from the machine bottom, arranged in two groups of three.

Machines without Cylinder Supports

Lifting from the center is safe with machines not equipped with cylinder supports.

Machines with Cylinder Supports

Be very careful when lifting machines with cylinder supports. Do not touch the supports during lifting to prevent machining damage. The forks must be clear of the support tubes. A wood block installed on the skid prevents fork insertion in the area of the supports and potential damage to the supports.

NOTE: Always lift the machine from the back of the Spectrum. The back of the Spectrum DOES NOT have the Spectrum nameplate. The back DOES have the stainless vacuum door on the electronics enclosure end of the machine (as shown in drawings below).

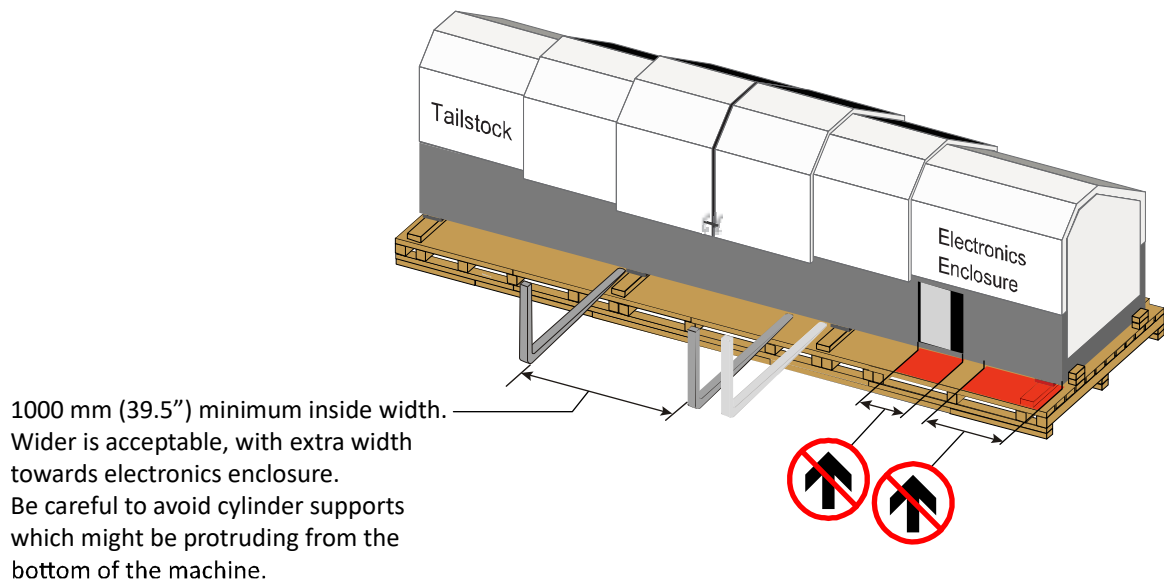

Packaging Spectrum

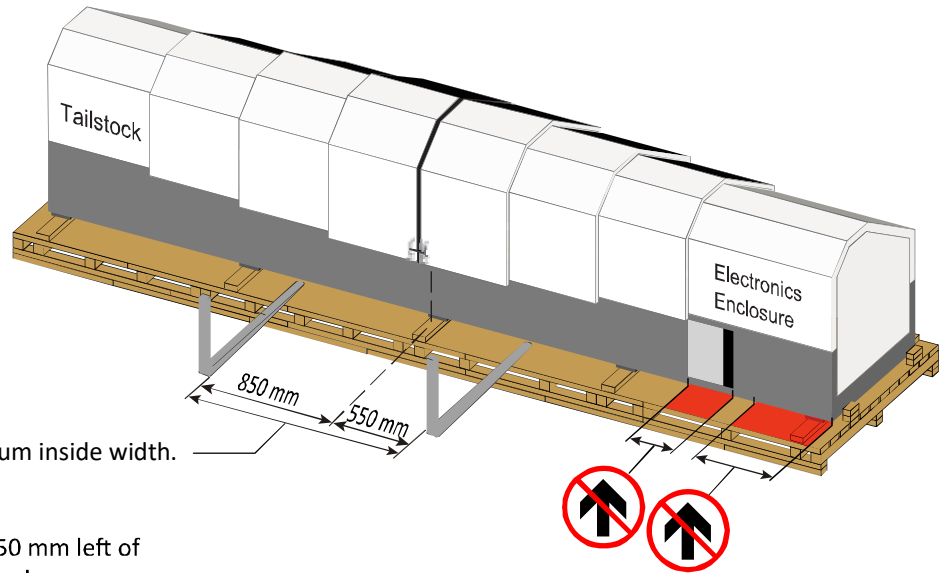

1400 mm (55") minimum inside width.
Wider is acceptable.

Forklift centerline is 150 mm left of
the center mounting pad.

Decorative Spectrum

After the machine has been uncrated, move the machine on its skid as close to its final location as possible.

Remove the four tie-down bars that secure the machine to the skid from all locations.

Set the machines on blocks when removed from the skid to provide clearance for further forklift operations.

Setting the Machine on Skates

After removing the machine from the skid, place the machine on skates or rolling trucks. This is the best option to move the machine into place.

Always use a piece of wood under the forks when lifting. The wood should be approximately the width of the engrave bed.

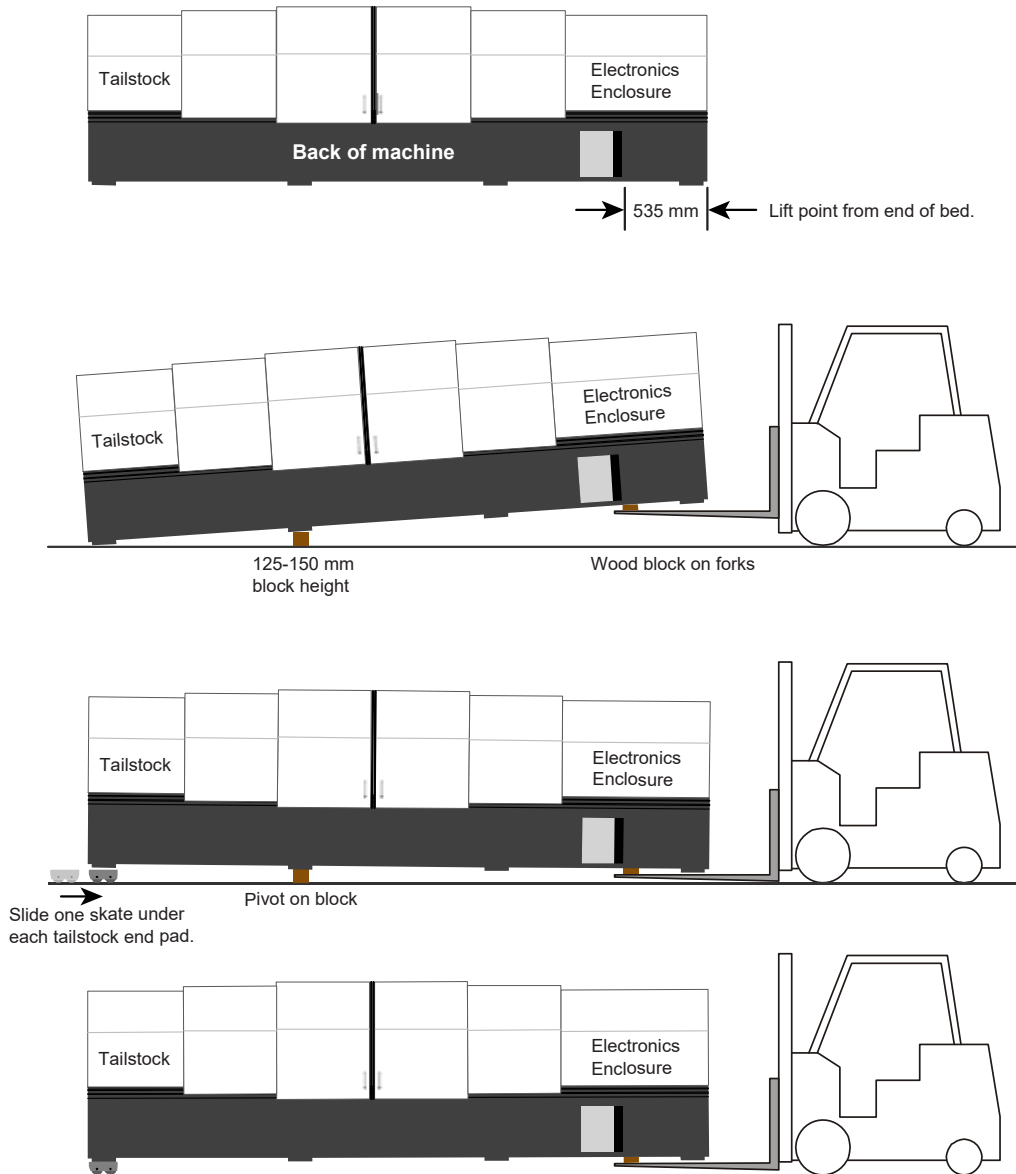

Moving Machine on Skates

The best option to move the machine is with skates under one end and a forklift pushing or pulling the machine. This option allows you to turn the machine around corners if necessary.

WARNING: Use care to keep the forks level when turning the machine. The narrow width of the Spectrum can make the machine tip if the forks are tipped up when making a turn.

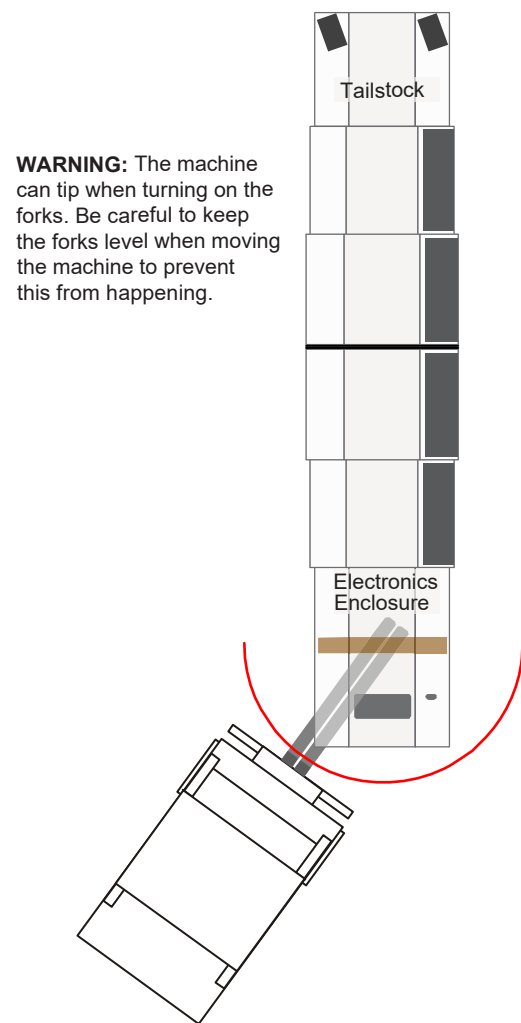
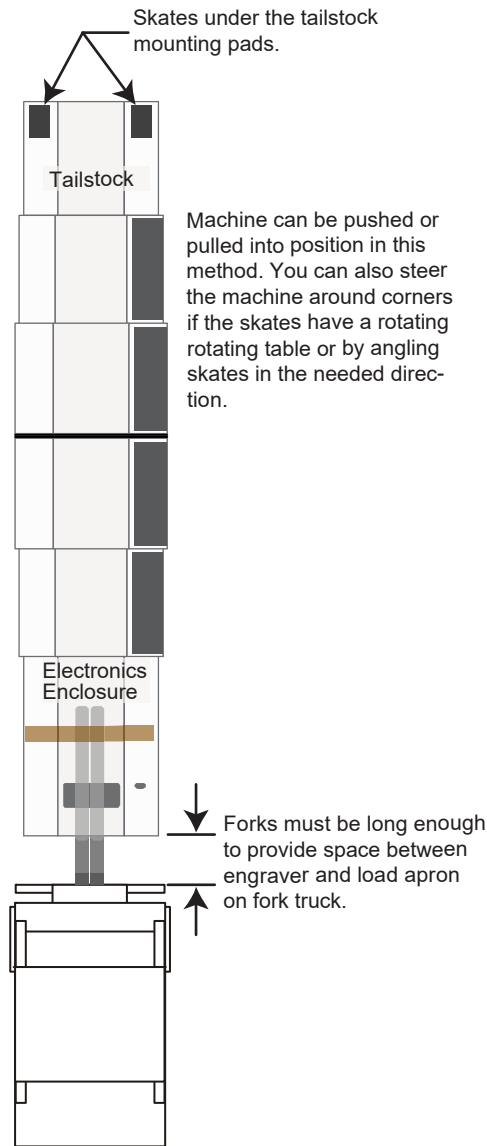

Shock Indicators

Shock indicators are attached to the inside of the engraver. These should be carefully inspected.

If an indicator shows the machine was subjected to excessive shock, do not proceed. Contact Ohio GT.



Not dropped



Dropped

Cylinder Information

Cylinder Plating and Finishing

The following information pertains to cylinder plating and finishing. This process is important to the engraving and printing quality of the cylinder.

■ Copper Hardness

Acceptable copper hardness is:

- 90-95 Rockwell on the Rockwell "B" scale

or

- 200-240 Vickers *see following note*

Note: It is important to understand that measured copper hardness does not indicate how well a cylinder will engrave. Grain structure has a large influence on the engravability of copper. Poor grain structure of the copper will cause hard copper to engrave poorly. Grain structure can be evaluated during engraving. How clean a cell engraves shows the grain structure of the copper. A small amount of burr around a cell indicates good grain structure.

■ Cylinder Preparation

While there are no standards for preparing a new steel cylinder before plating, many people grind the steel cylinder before plating. This removes machining marks on the cylinder. These marks can alter the way copper plates onto the cylinder. If the copper thickness is too thin, the machining marks can be seen in the engraving.

You may also want to use the same process when preparing to plate over copper, as machining marks in copper may also be seen in the engraving.

■ Cylinder Finishing

Both conventional grinding and machine finishing with diamond tools can be used. We recommend using all the stones when finishing with conventional grinding methods. Skipping stones increases the chance of grinding particles being left in the copper. Grinding particles can chip the diamond stylus, ruining the cylinder. To help prevent this, all coarse stone marks must be removed by the finer stones.

Polishing paste can be used immediately before engraving to remove any tarnish. Thoroughly remove all polishing paste before coating the cylinder with a lubricant. Polishing paste could damage the stylus if not completely removed.

■ Cylinder Concentricity

Cylinder concentricity plays a major role in engraving and printing quality. *Total indicated runout* or *TIR* creates problems during engraving. Printed density differences around the cylinder occur when TIR is present.

For best results, we strongly recommend holding the TIR to 0.05 mm (0.002 in) or less.

■ Cylinder Taper

Any cylinder taper can cause problems. The engraver is capable of engraving when minimal diametrical taper is present. Diametrical taper must be no more than 0.075 mm (0.003 in) over the cylinder length. Concave or convex tapers on the cylinder are unacceptable.

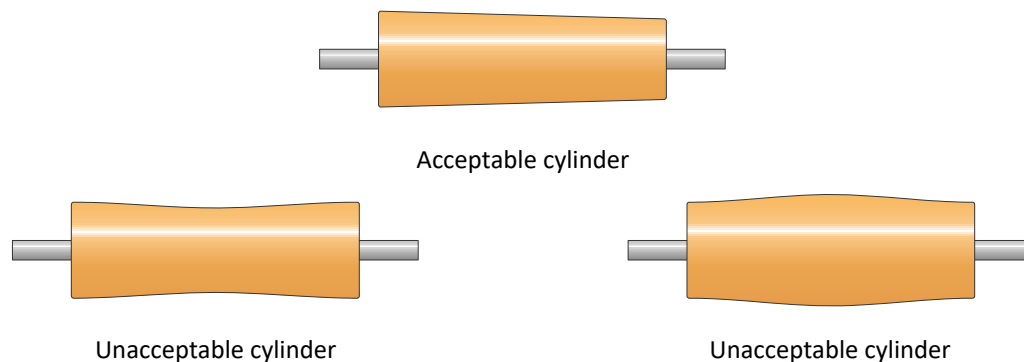

General

The following information are suggestions that you may wish to consider in planning your room layout and space requirements.

■ Storage

Different types of tools are provided with the engravers. To prevent these tools from being misplaced or coming up missing, a lockable storage cabinet is recommended.

A storage cabinet will also allow the various cylinder adapters used on the machine to be stored away safely. These adapters include cones, bearings, bearing shims and live centers

Depending on your safety codes, you may also need a cabinet suitable for the storage of flammable materials. The supplied lubricants (oil, grease) and the cylinder lubricant (Micropel) can be stored here.

Specifications

The following pages include specifications for the engraver, machine clearances, and machine connections location.

This page intentionally left blank

Machine Dimensions and Weight

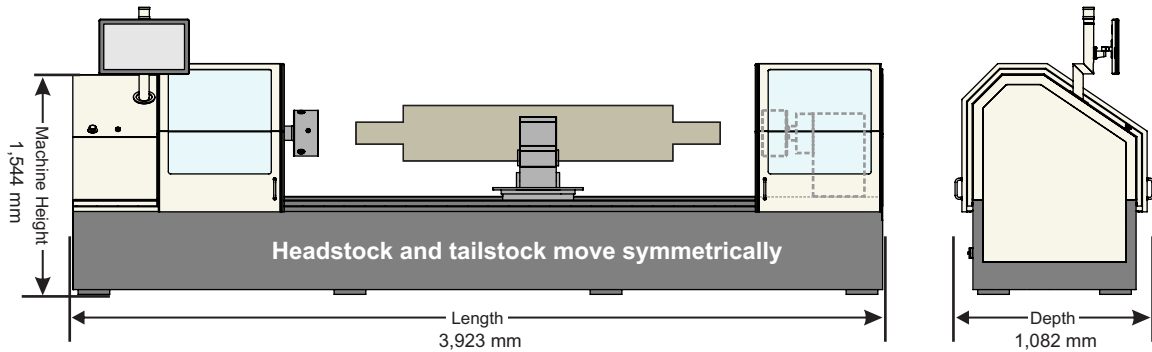

Cylinder Fixturing Options

Hollow Cylinder Direct Cones	Shafted Cylinder 3-Jaw Chuck 200 mm (8 inch)	Both Shafted and Hollow Inner/Outer Cones	Hollow Cylinders 3-Jaw Chuck with Cone/Arbor
--	---	---	---

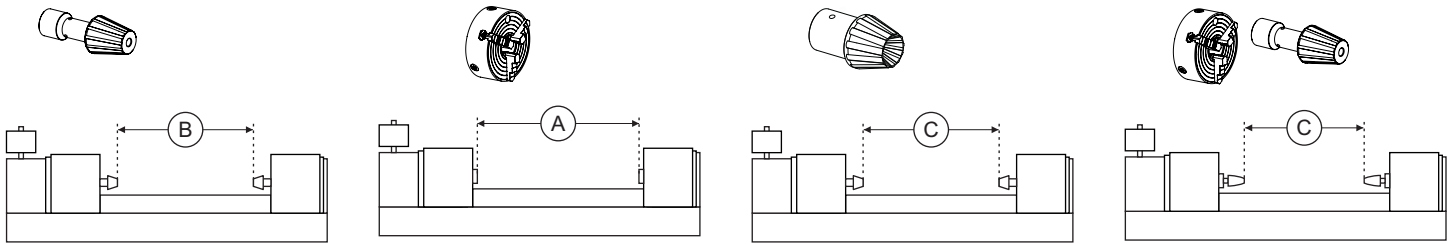

Max Overall Shafted

(A) —

Max Face Length

(C) 1400 mm

Bore range

56 mm - 124 mm

Max Overall Shafted

(A) 1700 mm

Max Face Length

(B) 1400 mm

Throat diameter

55 mm

Shaft diameter

10 - 100 mm

Max swallow depth

79 mm

Max Overall Shafted

(A) 1400 mm

Max Face Length

(B) 1400 mm

(C) 1400 mm

Bore Range (diameter)

Outer 75 - 115 mm

Shaft diameter

Inner 26 - 68 mm

Custom Design: Contact OHIO for specifications

Cylinder Data

Circumference range	350 - 1200 mm ⁽¹⁾
Weight maximum	500 kg
Allowable cylinder taper ⁽²⁾	75 µm
Allowable runout	50 µm
Copper hardness	190 to 230 HV
Deviation of copper hardness	+/-5 HV

Shafted Cylinders

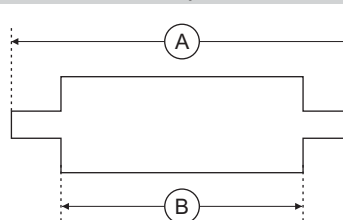

Hollow Cylinders

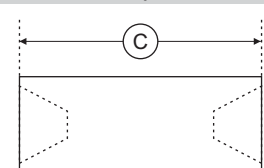

(1) Maximum physical cylinder sizes. Engraveable Circumferences depend upon applied engrave head, engraving frequency, screen, and screen angle range.
 (2) See Site Survey 9800-3143 for machine weight and other details



This page intentionally left blank

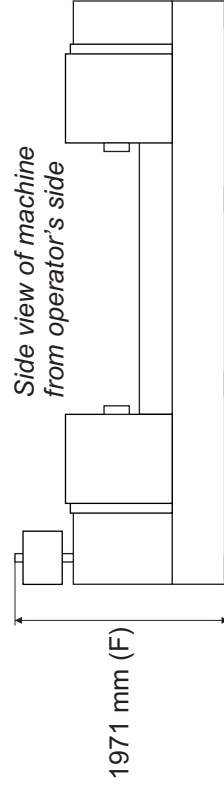
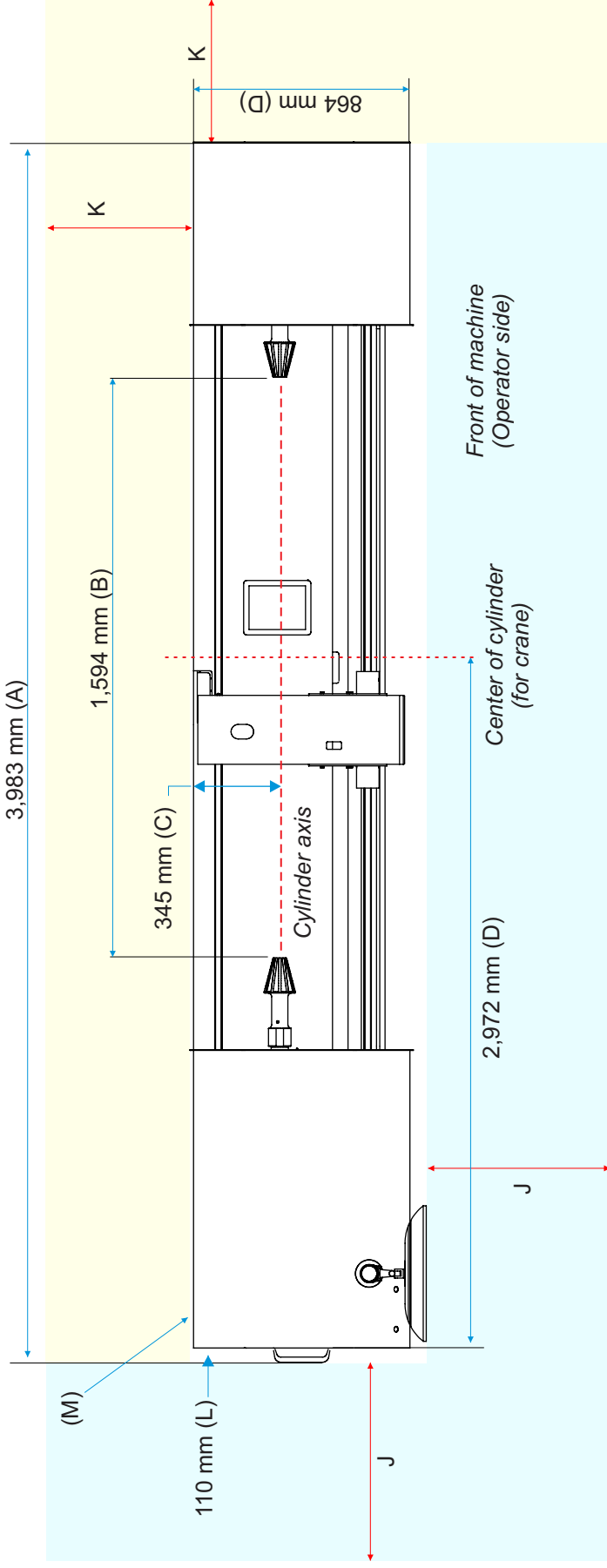

Side view of machine from operator's side

Headstock and tailstock move symmetrically.

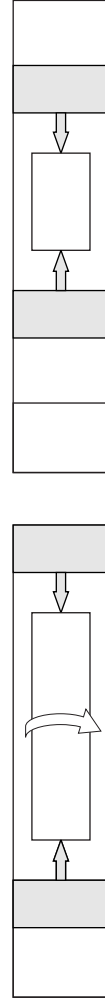

Cylinder rotates

A: Machine length

B: Distance from tip to tip, universal cones in chucks

C: Distance from back of machine to cylinder axis

D: Distance from left edge to cylinder center

E: Machine width

F: Distance to top of monitor post

J: Recommended clearance, front and left side:
1.5 meter

K: Recommended clearance, back and right side:
1 meter

L: Distance from end of machine to power and network connections

M: Power and network connection.
Recommended network: 1 GB
Minimum network: 100 MB



This page intentionally left blank

Machine Dimensions and Weight

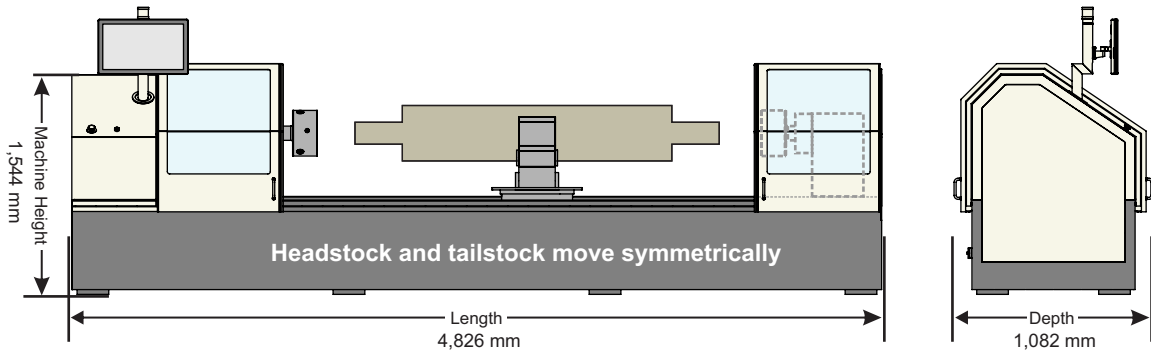

Cylinder Fixturing Options

Hollow Cylinder	Shafted Cylinder	Both Shafted and Hollow	Hollow Cylinders
Direct Cone	3-Jaw Chuck 200 mm (8 inch)	Inner/Outer Cone	3-Jaw Chuck with Cone/Arbor

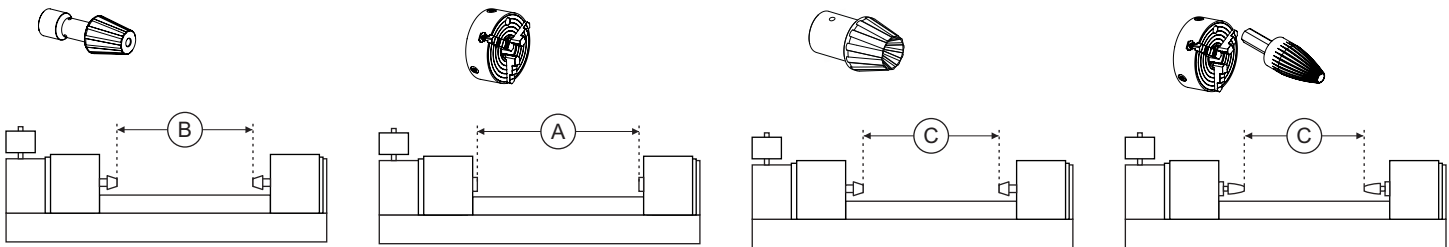

Max Overall Shafted

(A) —

Max Face Length

(C) 2300 mm

Bore range

55 - 125 mm

Max Overall Shafted

(A) 2350 mm

Max Face Length

(B) 1750 mm

Throat diameter

55 mm

Shaft diameter

10 - 100 mm

Max swallow depth

79 mm

Max Overall Shafted

(A) 2350 mm

Max Face Length

(B) 1750 mm

(C) 2200 mm

Bore Range (diameter)

Outer 75 - 115 mm

Shaft diameter

Inner 26 - 68 mm

Max Overall Shafted

(A) --

Max Face Length

(C) 2000 mm

Bore Range

41 - 114 mm

Cylinder Data

Circumference range	350 - 1500 mm ⁽¹⁾
Weight maximum	500 kg
Allowable cylinder taper ⁽²⁾	75 µm
Allowable runout	50 µm
Copper hardness	190 to 230 HV
Deviation of copper hardness	+/-5 HV

Shafted Cylinders

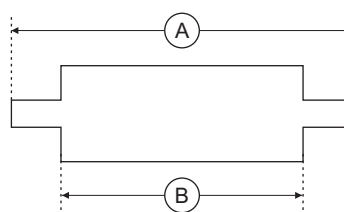

Hollow Cylinders

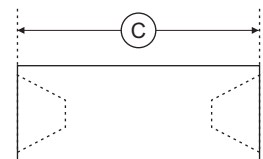

(1) Maximum physical cylinder sizes. Engraveable Circumferences depend upon applied engrave head, engraving frequency, screen, and screen angle range.
 (2) See Site Survey 9800-3143 for machine weight and other details



This page intentionally left blank

Top view of machine without enclosure doors

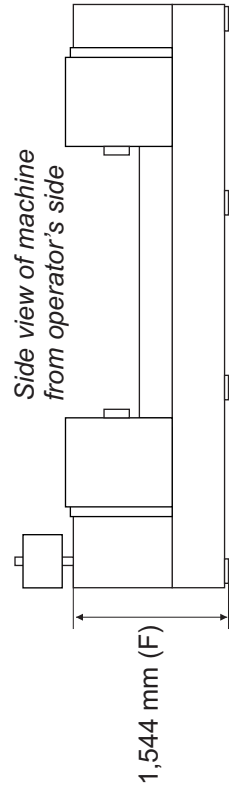
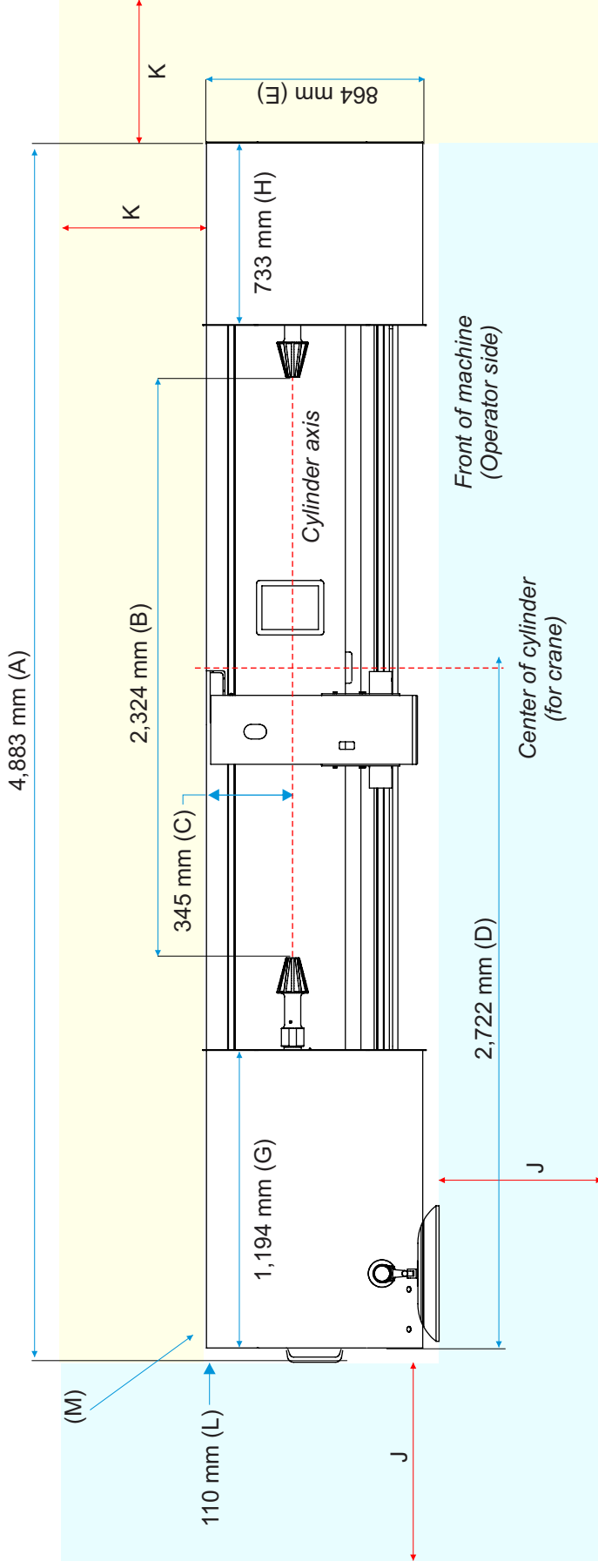

Headstock and tailstock move symmetrically.

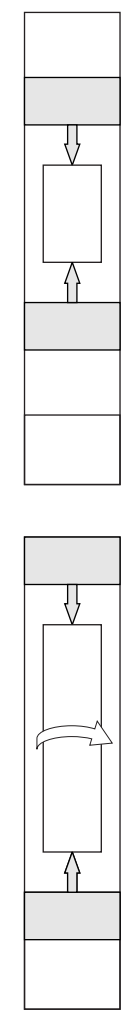

Cylinder rotates

- A: Machine length
- B: Distance from tip to tip, direct cone (55-125mm)
- C: Distance from back of machine to cylinder axis
- D: Distance from left edge to cylinder center
- E: Machine width
- F: Machine height (not including monitor)
- G: Width of cover over electronics end
- H: Width of cover at tailstock end
- J: Recommended clearance, front and left side: 1.5 meter
- K: Recommended clearance, back and right side: 1 meter
- L: Distance from end of machine to power and network connections
- M: Power and network connection. Recommended network: 1 GB Minimum network: 100 MB



This page intentionally left blank

Machine Dimensions and Weight

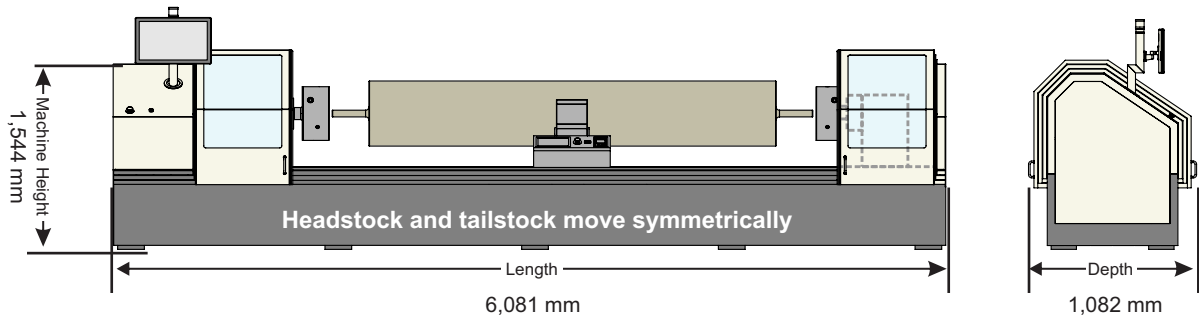

Cylinder Fixturing Options

Shafted Cylinder

3-Jaw Chuck
(315 mm)

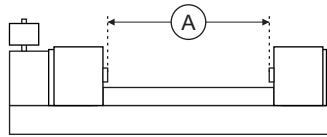

Max Overall Shafted

(A) 3600 mm

Max Face Length

(B) 3000 mm

Throat diameter

103 mm

Shaft diameter

10 - 165 mm

Max swallow depth

99 mm

Hollow Cylinders

3-Jaw Chuck (315 mm)
with Cone/Arbor

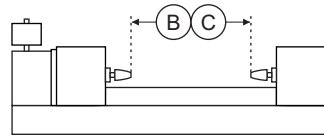
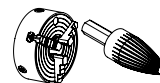

Max Overall Shafted

(A) --

Max Face Length

(C) 2500 mm

Bore Range

41 - 114 mm

Cylinder Data

Circumference range	350 - 1500 mm ⁽¹⁾
Weight maximum	500 kg
Allowable cylinder taper ⁽²⁾	75 µm
Allowable runout	50 µm
Copper hardness	190 to 230 HV
Deviation of copper hardness	+/-5 HV

Shafted Cylinders

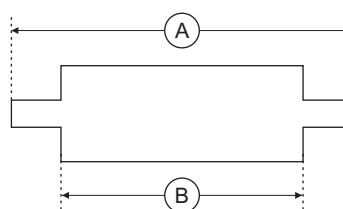

Hollow Cylinders

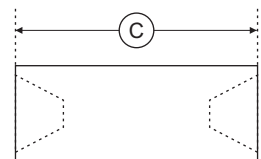

(1) Maximum physical cylinder sizes. Engraveable Circumferences depend upon applied engrave head, engraving frequency, screen, and screen angle range.
(2) See Site Survey 9800-3143 for machine weight and other details



This page intentionally left blank

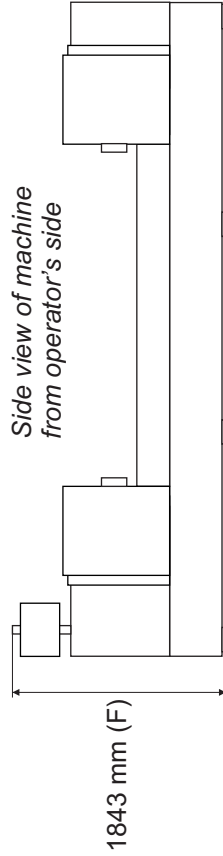
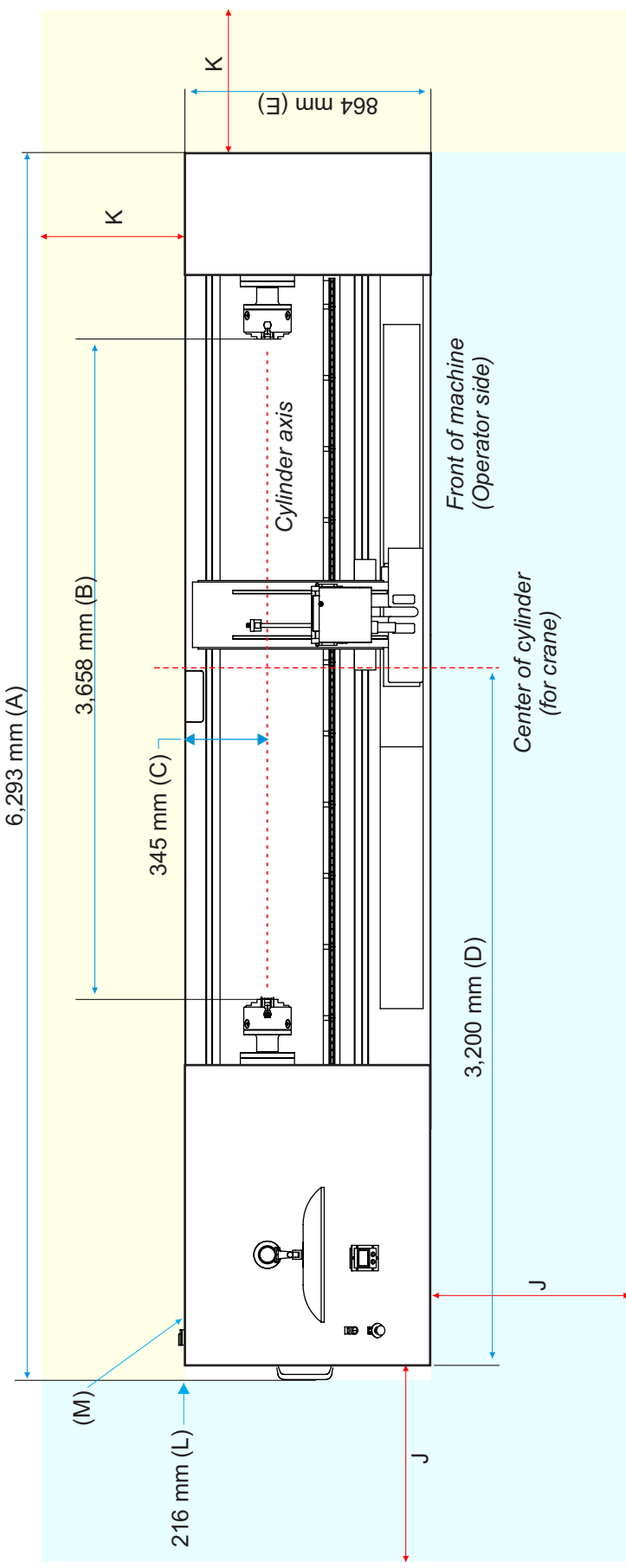

Headstock and tailstock move symmetrically.

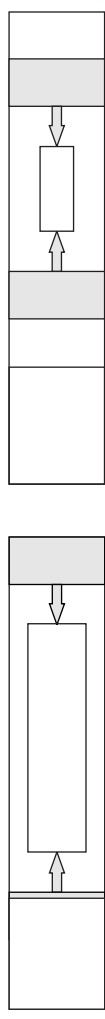

- A: Machine length
- B: Distance from edge to edge, chucks
- C: Distance from back of machine to cylinder axis
- D: Distance from left edge to cylinder center
- E: Machine width
- F: Distance to top of monitor post
- J: Recommended clearance, front and left side: 1.5 meter
- K: Recommended clearance, back and right side: 1 meter
- L: Distance from end of machine to power and network connections
- M: Power and network connection. Recommended network: 1 GB Minimum network: 100 MB



This page intentionally left blank

Machine Dimensions and Weight

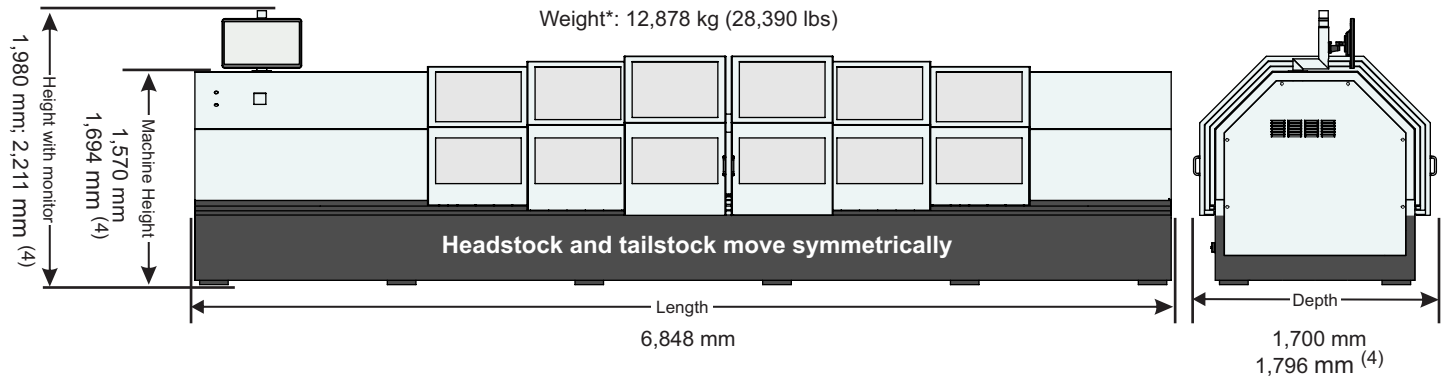

Cylinder Fixturing Options

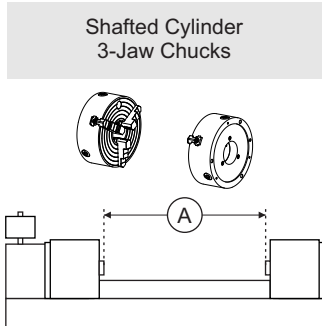

Cylinder Data

Circumference range	500 - 2,200 mm ⁽¹⁾
Weight maximum	1,300 kg
Allowable cylinder taper	75 μ m ⁽²⁾
Allowable runout	50 μ m
Copper hardness	190 to 230 HV
Deviation of copper hardness	+/- 5 HV

Shafted Cylinder

3-Jaw Chucks (315 mm)

Overall length (A)	950 - 3,600 mm
Face length (C)	350 - 3,000 mm
Shaft diameter (B)	30 - 75 mm

Shaft pass-through

Bore Diameter maximum (D)	100 mm
Bore Depth maximum, each end (E)	500 mm

Shaft clamping

Diameter typical range	30 - 150 mm
Diameter, maximum	250 mm ⁽³⁾

Large Circumference Option

Cylinder circumference: 600 - 2,500 mm

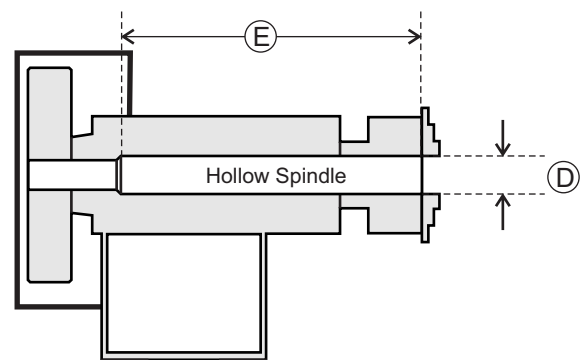
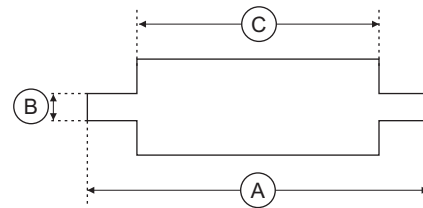

(1) Maximum physical cylinder sizes. Engraveable Circumferences depend upon applied engrave head, engraving frequency, screen, and screen angle range.

(2) See Site Survey 9800-3143 for details. (3) Requires a chuck jaw reconfiguration. (4) Dimensions with Large Circumference Option * Weight does not include cylinder



This page intentionally left blank

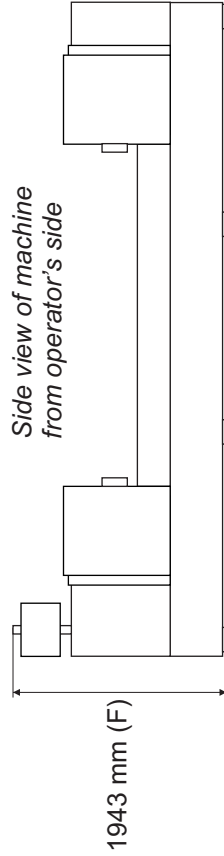
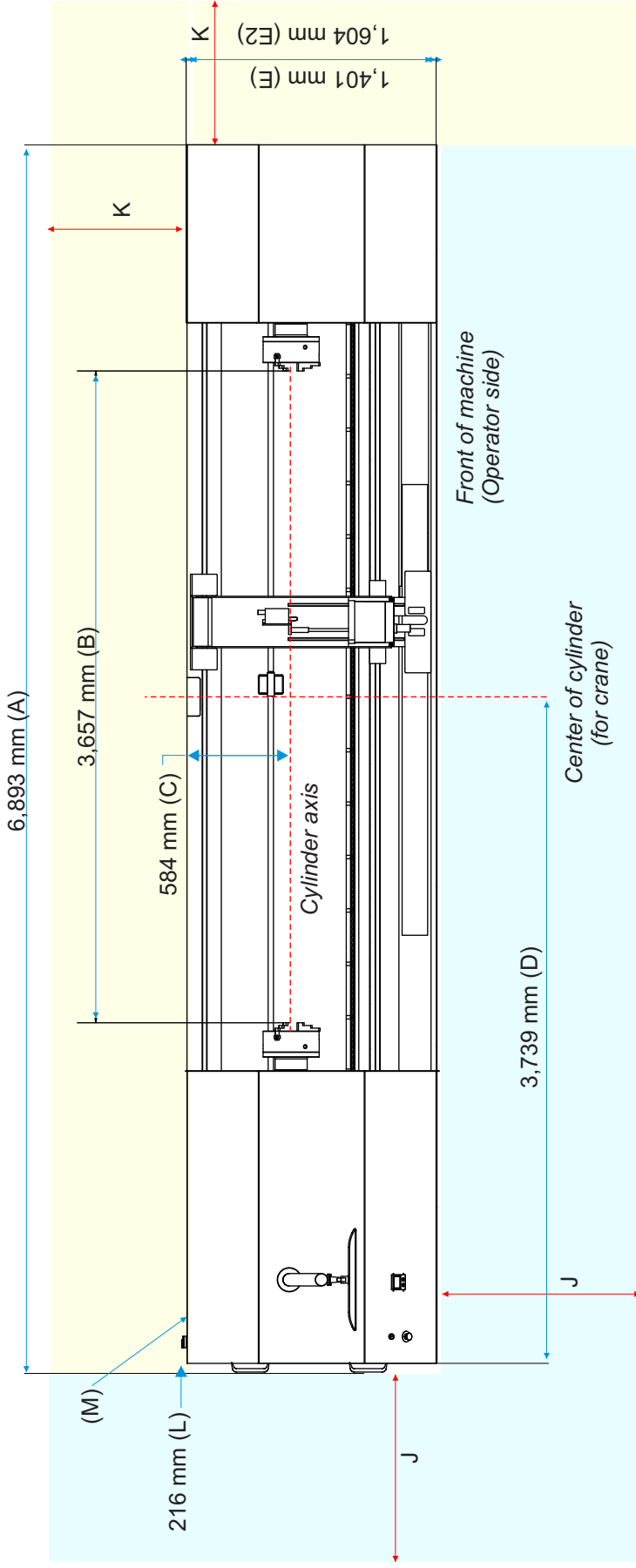

Headstock and tailstock move symmetrically.

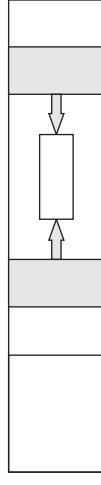

- A: Machine length
- B: Distance from edge to edge, chucks
- C: Distance from back of machine to cylinder axis
- D: Distance from left edge to cylinder center
- E: Machine width, standard
- E2: Machine width with large Cylinder Circumference option
- F: Distance to top of monitor post
- J: Recommended clearance, front and left side: 1.5 meter
- K: Recommended clearance, back and right side: 1 meter
- K: Distance from end of machine to power and network connections
- L: Power and network connection. Recommended network: 1 GB Minimum network: 100 MB



This page intentionally left blank

REVISION		
REV	DESCRIPTION	DATE
A	NEW DRAWING	12/91

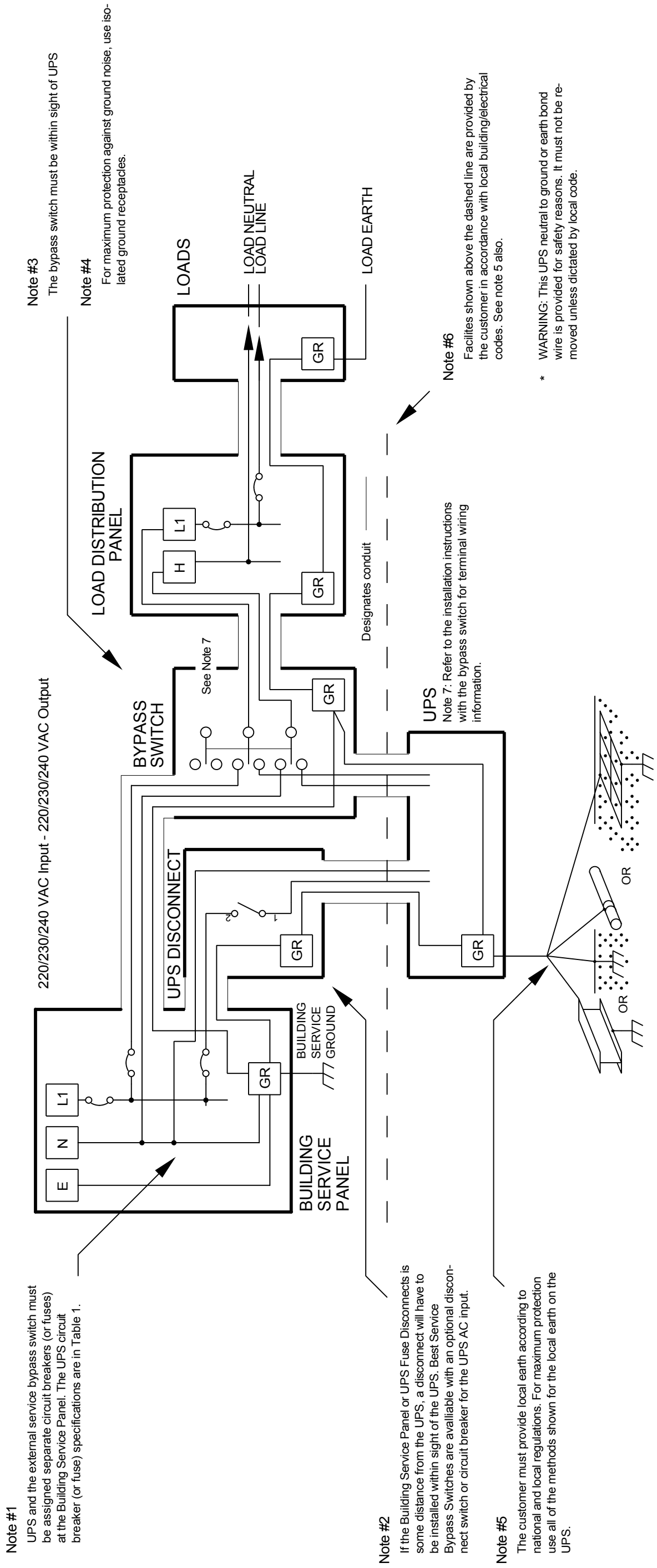

Note #1
UPS and the external service bypass switch must be assigned separate circuit breakers (or fuses) at the Building Service Panel. The UPS circuit breaker (or fuse) specifications are in Table 1.

Note #2
If the Building Service Panel or UPS Fuse Disconnects is some distance from the UPS, a disconnect will have to be installed within sight of the UPS. Best Service Bypass Switches are available with an optional disconnect switch or circuit breaker for the UPS AC input.

Note #3
The bypass switch must be within sight of UPS

Note #4
For maximum protection against ground noise, use isolated ground receptacles.

Note #5
The customer must provide local earth according to national and local regulations. For maximum protection use all of the methods shown for the local earth on the UPS.

Note #6
Facilities shown above the dashed line are provided by the customer in accordance with local building/electrical codes. See note 5 also.

Note #7
Refer to the installation instructions with the bypass switch for terminal wiring information.

*** WARNING:** This UPS neutral to ground or earth bond wire is provided for safety reasons. It must not be removed unless dictated by local code.

NOTE: You must use the specified AC input service. The line service requirements for the UPS are calculated for nominal AC input voltage and full rated load with the battery charger operating on maximum charge. Use applicable local or national codes when determining size of circuit breaker or fuse.

* = Circuit breaker or fuse size should correspond to service requirement. Use next larger available circuit breaker or fuse rating if exact match cannot be found.

This earth connection must be made.



TITLE		220V 50Hz 850VA UPS INSTALLATION	
UNLESS OTHERWISE SPECIFIED: DIMENSIONS ARE IN INCHES RESISTANCE IS IN OHMS CAPACITANCE IS IN MICROFARADS	SCALE	SHT NO	1 OF 1
DR	RELEASE DATE	SIZE	B
CHK'D	DATE	DWG NO	9400-0002
ENGR	APPROVALS	REV	A
DATE			

THIS INFORMATION IS THE CONFIDENTIAL, RESTRICTED AND SOLE PROPERTY OF DAETWYLER R&D CORP. IT SHALL BE USED BY THE RECIPIENT FOR PURPOSES BENEFITING AND/OR APPROVED BY MDC. IT SHALL NOT BE DISCLOSED, REPRODUCED OR USED WITHOUT PRIOR WRITTEN APPROVAL OF DAETWYLER R&D CORPORATION.

DOCUMENT CONTROL DATE	
-----------------------	--



This page intentionally left blank